



[Http://www.mideaircon.com](http://www.mideaircon.com)

# *Service manual*

*Room airconditioner*

*Split Wall-Mounted Type*



*Applied to:*

MSV1-07CRN1	MSV1-07HRN1
MSV1-09CRN1	MSV1-09HRN1
MSV1-12CRN1	MSV1-12HRN1

## NOTE:

---

Before servicing the unit, please read this at first.  
Always contact with your service center if meet problem.



# Content

<b>1</b>	<b>Precaution .....</b>	<b>1</b>
1.1	Safety Precaution .....	1
1.2	Warning .....	1
1.3	Function .....	4
<b>2</b>	<b>Dimension .....</b>	<b>5</b>
<b>3</b>	<b>Specification .....</b>	<b>6</b>
<b>4</b>	<b>Operation limits .....</b>	<b>9</b>
<b>5</b>	<b>Wiring diagram.....</b>	<b>10</b>
<b>6</b>	<b>Installation details.....</b>	<b>12</b>
6.1	Wrench torque sheet for installation .....	12
6.2	Connecting the cables .....	12
6.3	Pipe length and the elevation .....	12
6.4	Air purging of the piping and indoor unit.....	13
6.5	Pumping down (Re-installation) .....	15
6.6	Re-air purging (Re-installation) .....	16
6.7	Balance refrigerant of the 2-way, 3-way valves .....	17
6.8	Evacuation .....	18
6.9	Gas charging.....	19
<b>7</b>	<b>Electronic function .....</b>	<b>20</b>
7.1	Electronic control working environment.....	20
7.2	Proper symbols and their meaning.....	20
7.3	Function .....	21
7.4	Protection .....	21
7.5	Fan only mode .....	22
7.6	Cooling mode .....	22
7.7	Dehumidifying mode .....	23
7.8	Heating mode.....	23
7.9	Defrosting mode(available for heating mode).....	24
7.10	Auto mode .....	25
7.11	Force cooling function .....	25
7.12	Sleep mode .....	26
7.13	Auto restart function .....	27
7.14	Ionizer (air clean) function.....	27
<b>8</b>	<b>Model and Parameters .....</b>	<b>28</b>
<b>9</b>	<b>Troubleshooting.....</b>	<b>29</b>
9.1	LCD Display board .....	29
9.2	Indoor Unit Error Display .....	30
9.3	Diagnostic chart .....	30
9.4	Resetting phenomenon often occurs during operation. ....	31
9.5	Operation lamp flashes and Timer lamp off.....	31
9.6	Operation lamp flashes and Timer lamp on.....	32
9.7	Operation lamp off and Timer lamp flashes.....	32
9.8	Operation lamp on and Timer lamp flashes.....	32
9.9	Operation lamp flashes, Timer lamp flashes .....	32



# 1 Precaution

## 1.1 Safety Precaution

- **To prevent injury to the user or other people and property damage, the following instructions must be followed.**
- **Incorrect operation due to ignoring instruction will cause harm or damage.**
- **Before service unit, be sure to read this service manual at first.**

## 1.2 Warning

### ➤ Installation

- **Do not use a defective or underrated circuit breaker. Use this appliance on a dedicated circuit.**  
There is risk of fire or electric shock.
- **For electrical work, contact the dealer, seller, a qualified electrician, or an Authorized service center.**  
Do not disassemble or repair the product, there is risk of fire or electric shock.
- **Always ground the product.**  
There is risk of fire or electric shock.
- **Install the panel and the cover of control box securely.**  
There is risk of fire of electric shock.
- **Always install a dedicated circuit and breaker.**  
Improper wiring or installation may cause fire or electric shock.
- **Use the correctly rated breaker or fuse.**  
There is risk of fire or electric shock.
- **Do not modify or extend the power cable.**  
There is risk of fire or electric shock.
- **Do not install, remove, or reinstall the unit by yourself (customer).**  
There is risk of fire, electric shock, explosion, or injury.
- **Be caution when unpacking and installing the product.**  
Sharp edges could cause injury, be especially careful of the case edges and the fins on the condenser and evaporator.
- **For installation, always contact the dealer or an Authorized service center.**  
There is risk of fire, electric shock, explosion, or injury.
- **Do not install the product on a defective installation stand.**  
It may cause injury, accident, or damage to the product.
- **Be sure the installation area does not deteriorate with age.**  
If the base collapses, the air conditioner could fall with it, causing property damage, product failure, and personal injury.
- **Do not let the air conditioner run for a long time when the humidity is very high and a door or windows is left open.**  
Moisture may condense and wet or damage furniture.
- **Take care to ensure that power cable could not be pulled out or damaged during operation.**  
There is risk of fire or electric shock.

- **Do not place anything on the power cable.**  
There is risk of fire or electric shock.
- **Do not plug or unplug the power supply plug during operation.**  
There is risk of fire or electric shock.
- **Do not touch (operation) the product with wet hands.**  
There is risk of fire or electric shock.
- **Do not place a heater or other appliance near the power cable.**  
There is risk of fire and electric shock.
- **Do not allow water to run into electric parts.**  
It may cause fire, failure of the product, or electric shock.
- **Do not store or use flammable gas or combustible near the product.**  
There is risk of fire or failure of product.
- **Do not use the product in a tightly closed space for a long time.**  
Oxygen deficiency could occur.
- **When flammable gas leaks, turn off the gas and open a window for ventilation before turn the product on.**  
Do not use the telephone or turn switches on or off.  
There is risk of explosion or fire.
- **If strange sounds, or small or smoke comes from product. Turn the breaker off or disconnect the power supply cable.**  
There is risk of electric shock or fire.
- **Stop operation and close the window in storm or hurricane. If possible, remove the product from the window before the hurricane arrives.**  
There is risk of property damage, failure of product, or electric shock.
- **Do not open the inlet grill of the product during operation. (Do not touch the electrostatic filter, if the unit is so equipped).**  
There is risk of physical injury, electric shock, or product failure.
- **When the product is soaked (flooded or submerged), contact an Authorized service center.**  
There is risk of fire or electric shock.
- **Be caution that water could not enter the product.**  
There is risk of fire, electric shock, or product damage.
- **Ventilate the product from time to time when operating it together with a stove, etc.**  
There is risk of fire or electric shock.
- **Turn the main power off when cleaning or maintaining the product.**  
There is risk of electric shock.
- **When the product is not be used for a long time, disconnect the power supply plug or turn off the breaker.**  
There is risk of product damage or failure, or unintended operation.
- **Take care to ensure that nobody could step on or fall onto the outdoor unit.**  
This could result in personal injury and product damage.

## ➤ CAUTION

- **Always check for gas (refrigerant) leakage after installation or repair of product.**  
Low refrigerant levels may cause failure of product.
- **Install the drain hose to ensure that water is drained away properly.**  
A bad connection may cause water leakage.
- **Keep level even when installing the product.**  
To avoid vibration of water leakage.
- **Do not install the product where the noise or hot air from the outdoor unit could damage the neighborhoods.**  
It may cause a problem for your neighbors.

- **Use two or more people to lift and transport the product.**  
Avoid personal injury.
- **Do not install the product where it will be exposed to sea wind (salt spray) directly.**  
It may cause corrosion on the product. Corrosion, particularly on the condenser and evaporator fins, could cause product malfunction or inefficient operation.

## ➤ Operational

- **Do not expose the skin directly to cool air for long periods of time. (Do not sit in the draft).**  
This could harm to your health.
- **Do not use the product for special purposes, such as preserving foods, works of art, etc. It is a consumer air conditioner, not a precision refrigerant system.**  
There is risk of damage or loss of property.
- **Do not block the inlet or outlet of air flow.**  
It may cause product failure.
- **Use a soft cloth to clean. Do not use harsh detergents, solvents, etc.**  
There is risk of fire, electric shock, or damage to the plastic parts of the product.
- **Do not touch the metal parts of the product when removing the air filter. They are very sharp.**  
There is risk of personal injury.
- **Do not step on or put anything on the product. (outdoor units)**  
There is risk of personal injury and failure of product.
- **Always insert the filter securely. Clean the filter every two weeks or more often if necessary.**  
A dirty filter reduces the efficiency of the air conditioner and could cause product malfunction or damage.
- **Do not insert hands or other object through air inlet or outlet while the product is operated.**  
There are sharp and moving parts that could cause personal injury.
- **Do not drink the water drained from the product.**  
It is not sanitary could cause serious health issues.
- **Use a firm stool or ladder when cleaning or maintaining the product.**  
Be careful and avoid personal injury.
- **Replace the all batteries in the remote control with new ones of the same type. Do not mix old and new batteries or different types of batteries.**  
There is risk of fire or explosion.
- **Do not recharge or disassemble the batteries. Do not dispose of batteries in a fire.**  
They may burn or explode.
- **If the liquid from the batteries gets onto your skin or clothes, wash it well with clean water. Do not use the remote of the batteries have leaked.**  
The chemical in batteries could cause burns or other health hazards.

## 1.3 Function

### ➤ Indoor unit

- 1. Operation ON/OFF by remote controller**
- 2. Sensing by room temperature**  
Room temperature sensor. Pipe temperature sensor.
- 3. Room temperature control**  
Maintain the room temperature in accordance with the setting temperature.
- 4. Starting temperature control**  
Indoor fan is delayed for 5 sec at the starting.
- 5. Time Delay Safety control**  
Restarting is for approx. 3 minutes.
- 6. Indoor fan speed control**  
Turbo, high, med, low, breeze.
- 7. Operation indication LCD**  
Light up in the LCD for each operation mode.
- 8. Two-direction air vane**  
The unit will decide the louver direction according to operation mode.
- 9. Sleep mode auto control**  
The fan is turn to low speed (cooling/heating).  
The unit will be turn off after seven hours.
- 10. Independent dehumidification**  
The function is usually used in rainy days in springtime or damp areas
- 11. Self-diag. function**  
The function will be operate in any operation mode.
- 12. Air flow Direction control**  
The louver can be set at the desired position or swing up and down automatically
- 13. Auto mode**  
The unit can be change by the room temperature.
- 14. Anti-cold function**  
Prevent the cold wind at the beginning of unit start.
- 15. Temp. Compensation**
- 16. Defrost mode**
- 17. Auto-restart function**
- 18. Flexible wiring connection**
- 19. Self-Clean**

### **20. Ionizer**

The function will be operated by remote controller

### ➤ Outdoor unit

- 1. Power relay control**  
The unit has 3 mins delay between continuously ON/OFF operations.
- 2. Low noise air flow system**  
Bird tail propeller fan makes the outdoor unit run more quietly
- 3. Hydrophilic aluminum fin**  
The hydrophilic fin can improve the heating efficiency at operation mode.
- 4. 4 way valve control**  
It is only operated in the heating operation mode except defrosting operation.
- 5. Anti-rust cabinet**  
Made from electrolytic zinc steel sheet and anti-rust coated components.
- 6. Valve protection cover**  
It protects the valves and prevents water from dripping.
- 7. Discharge pipe temperature**



## 2 Dimension

### Indoor unit



Mode \ Dimension	W	H	D
7K	795	270	165
9K	795	270	165
12K	845	286	165

### outdoor unit

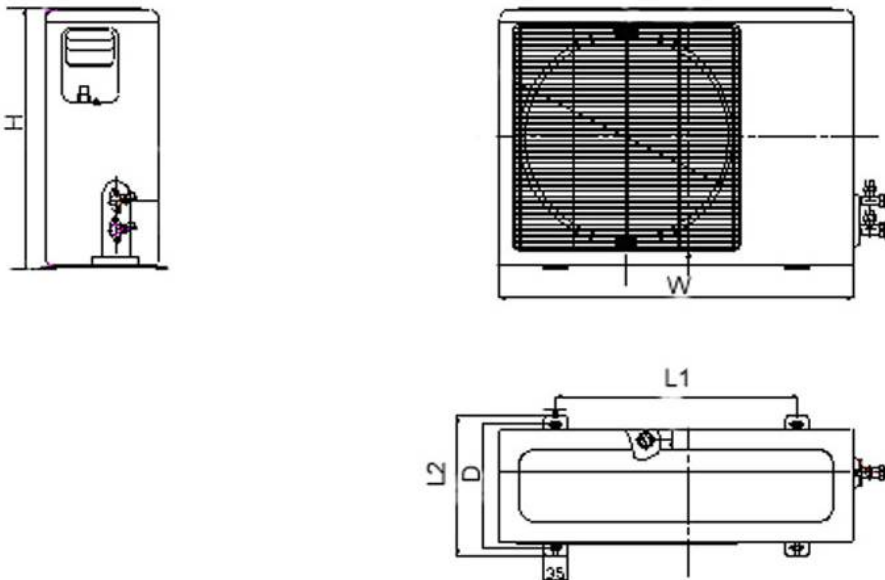

Mode \ Dimension	W	H	D	L1	L2
7K	700	535	285	458	250
9K	780	540	250	549	266
12K	780	540	250	549	266

### 3 Specification

Model		MSV1-07CRN1	MSV1-07HRN1	MSV1-09CRN1	MSV1-09HRN1	
<b>Power supply</b>		<b>Ph-V-Hz</b>	1, 220-240V~, 50Hz	1, 220-240V~, 50Hz	1, 220-230V~, 50Hz	1, 220-230V~, 50Hz
Cooling	Capacity	Btu/h	7000	7000	9000	9000
	Input	W	640	640	820	820
	Rated current	A	2.8	2.8	3.6	3.6
	EER	Btu/w.h	10.9	10.9	3.2, 10.9	3.2, 10.9
Heating	Capacity	Btu/h	—	8000	—	10300
	Input	W	—	650	—	840
	Rated current	A	—	2.9	—	3.7
	COP	W/W	—	12.31	—	12.28
Max. current		A	5	5	5	6
Starting current		A	15	15	21.7	21.7
Compressor	Model		PA82X1C-4DZDE	PA82X1C-4DZDE	PA108X1C-4FTDE	PA108X1C-4FTDE
	Type		ROTARY	ROTARY	ROTARY	ROTARY
	Brand		TOSHIBA	TOSHIBA	TOSHIBA	TOSHIBA
	Capacity	Btu/h	6650	6650	8870	8870
	Input	W	680	680	915	915
	Rated current(RLA)	A	3.04/2.85	2.85	4	4
	Locked rotor Amp(LRA)	A	15	15	21.7	21.7
	Thermal protector		B135-135-241E/MRA1340	B135-241E/MRA1340	B135-241E/MRA1343	B135-241E/MRA1343
	Capacitor	uF	25	25	25	25
Refrigerant oil	ml	ESTER OIL VG74 35	ESTER OIL VG74 35	ESTER OIL VG74 35	ESTER OIL VG74 35	
Indoor fan motor	Model		RPG20D	RPG20D	RPG20D	RPG20D
	Brand		Welling	Welling	Welling	Welling
	Input	W	32	32	38	38
	Capacitor	uF	1.2	1.2	1.2	1.2
	Speed(hi/mi/lo)	r/min	1040/900/800	1040/900/800	1040/900/800	1040/900/800
Indoor air flow (Hi/Mi/Lo)		m <sup>3</sup> /h	450	450	550	550
Indoor noise level (Hi/Mi/Lo)		dB(A)	36/33/30	36/33/30	38/35/32	38/35/32
Outdoor fan motor	Model		YDK24-6T	YDK24-6T	YDK24-6F	YDK24-6F
	Brand		Welling	Welling	Welling	Welling
	Input	W	56	56	56	56
	Capacitor	uF	2.5	2.5	2.5	2.5
	Speed	r/min	800	800	800	800
Outdoor air flow		m <sup>3</sup> /h	1500	1500	1800	1800
Outdoor noise level		dB(A)	54	54	54	54
Refrigerant type R410A		g	R410A/800	R410A/820	R410A/900	R410A/900
Design pressure		MPa	4.2	4.2	4.2	4.2
Refrigerant piping	Liquid side/ Gas side	mm	Φ6.35/Φ9.53	Φ6.35/Φ9.53	Φ6.35/Φ9.53	Φ6.35/Φ9.53
	Max. refrigerant pipe length	m	10	10	10	10
	Max. difference in level	m	5	5	5	5
Operation temp		℃	17-30	17-30	17-30	17-30
Ambient temp		℃	18-43	-7-43	18-43	-7-43
Application area		m <sup>2</sup>	10-14	10-14	14-21	14-21

**Note:**

The noise data is based on hemi-anechoic chamber, during actual operation; these values are normally somewhat different as a result of ambient condition.

The above design and specifications are subject to change without prior notice for product improvement.

Model			MSV1-12CRN1	MSV1-12HRN1
<b>Power supply</b>		<b>Ph-V-Hz</b>	1, 220-240V~, 50Hz	1, 220-240V~, 50Hz
Cooling	Capacity	Btu/h	12000	12000
	Input	W	1090	1100
	Rated current	A	4.8	4.8
	EER	Btu/w.h	3.23, 11.0	3.2, 10.9
Heating	Capacity	Btu/h	—	13000
	Input	W	—	1050
	Rated current	A	—	4.6
	COP	W/W	—	12.38
Max. current		A	8	8
Starting current		A	26	26
Compressor	Model		PA140X2C-4FT	PA140X2C-4FT
	Type		ROTARY	ROTARY
	Brand		TOSHIBA	TOSHIBA
	Capacity	Btu/h	11567/11618	11567/11618
	Input	W	1145/1185	1145/1185
	Rated current(RLA)	A	5.3/5.15	5.3/5.15
	Locked rotor Amp(LRA)	A	26	26
	Thermal protector		UP3RE0596-T56 (INTERNAL: IOL)	UP3RE0596-T56 (INTERNAL: IOL)
	Capacitor	uF	35	35
Refrigerant oil	ml	RB68AF/T68/a68TF: 480	RB68AF/T68/a68TF: 480	
Indoor fan motor	Model		RPG20D	RPG20D
	Brand		Welling	Welling
	Input	W	38	38
	Capacitor	uF	1.2	1.2
	Speed(hi/mi/lo)	r/min	1260/1080/900	1260/1080/900
Indoor air flow (Hi/Mi/Lo)		m <sup>3</sup> /h	650	650
Indoor noise level (Hi/Mi/Lo)		dB(A)	40/37/34	40/37/34
Outdoor fan motor	Model		YDK24-6F	YDK24-6F
	Brand		Welling	Welling
	Input	W	56	56
	Capacitor	uF	2.5	2.5
	Speed	r/min	800	800
Outdoor air flow		m <sup>3</sup> /h	1800	1800
Outdoor noise level		dB(A)	55	55
Refrigerant type R410A		g	R410A/1050	R410A/1050
Design pressure		MPa	4.2	4.2
Refrigerant piping	Liquid side/ Gas side	mm	Φ6.35/Φ12.7	Φ6.35/Φ12.7
	Max. refrigerant pipe length	m	10	10
	Max. difference in level	m	5	5
Operation temp		℃	17-30	17-30
Ambient temp		℃	17-30	-7-43
Application area		m <sup>2</sup>	18-26	18-26

**Note:**

The noise data is based on hemi-anechoic chamber, during actual operation; these values are normally somewhat different as a result of ambient condition.

The above design and specifications are subject to change without prior notice for product improvement.

## Refrigerant cycle diagram

### ➤ Cooling only

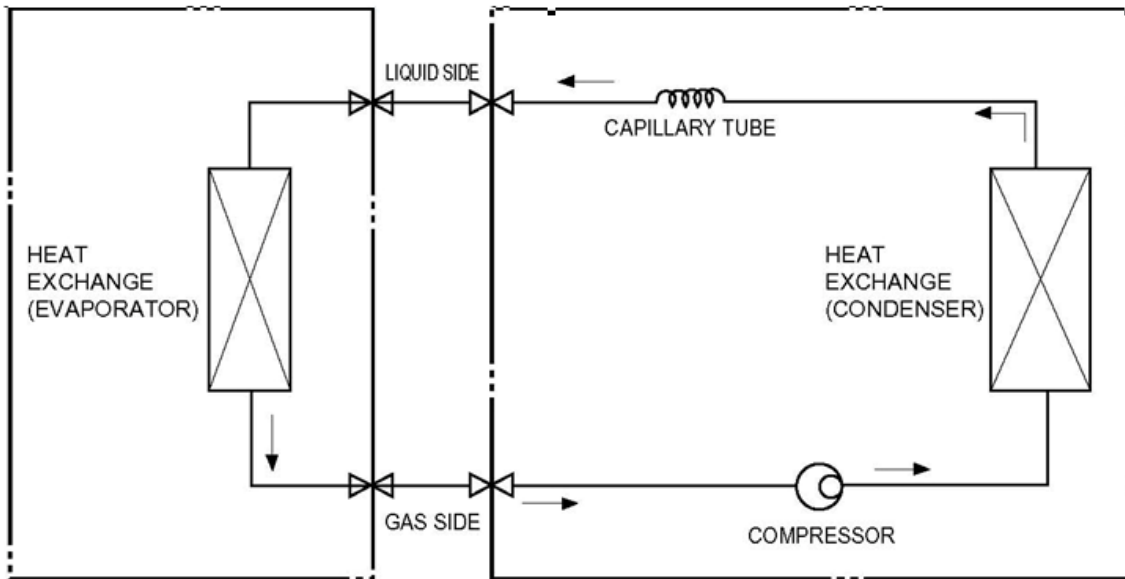

### ➤ Heat pump mode

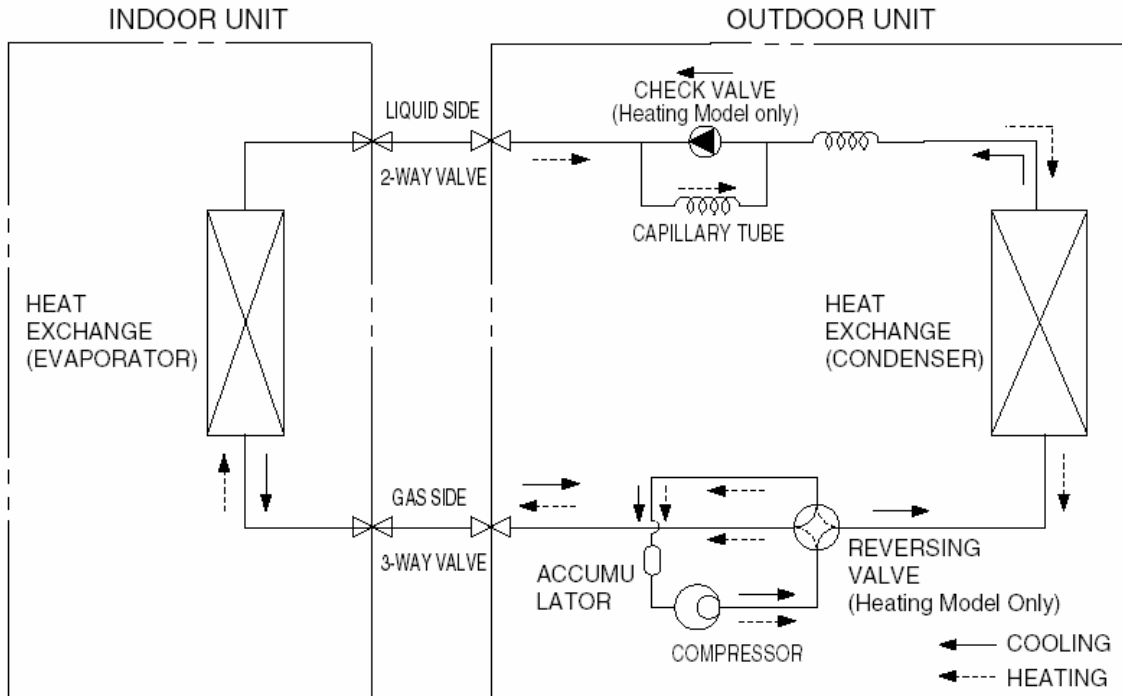

# 4 Operation limits

## Cooling operation

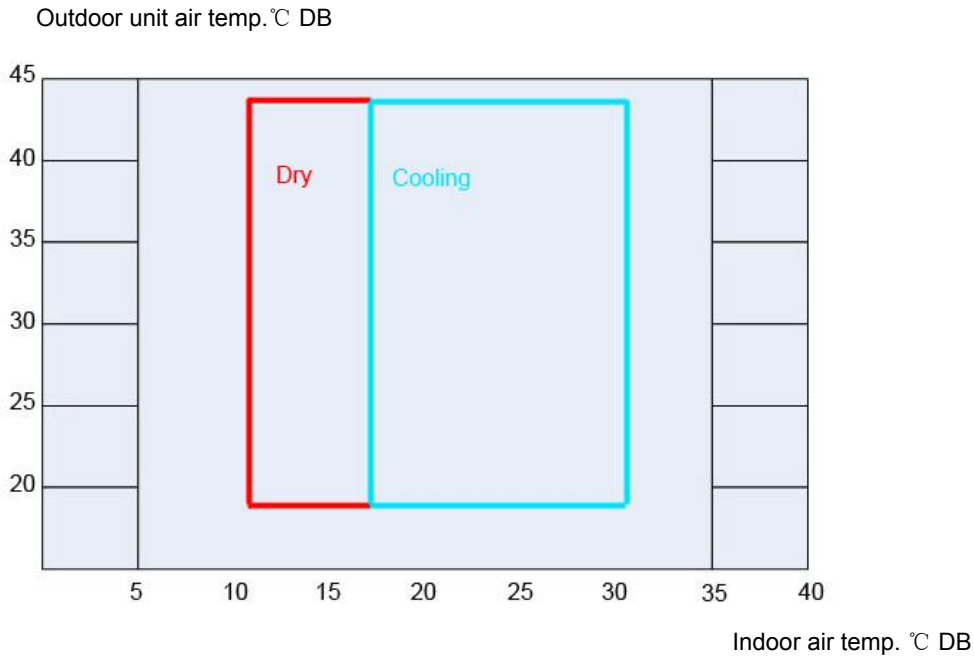

**Note:** The chart is the result from the continuous operation under constant air temperature conditions. However, excludes the initial pull-down stage.

## Heating operation

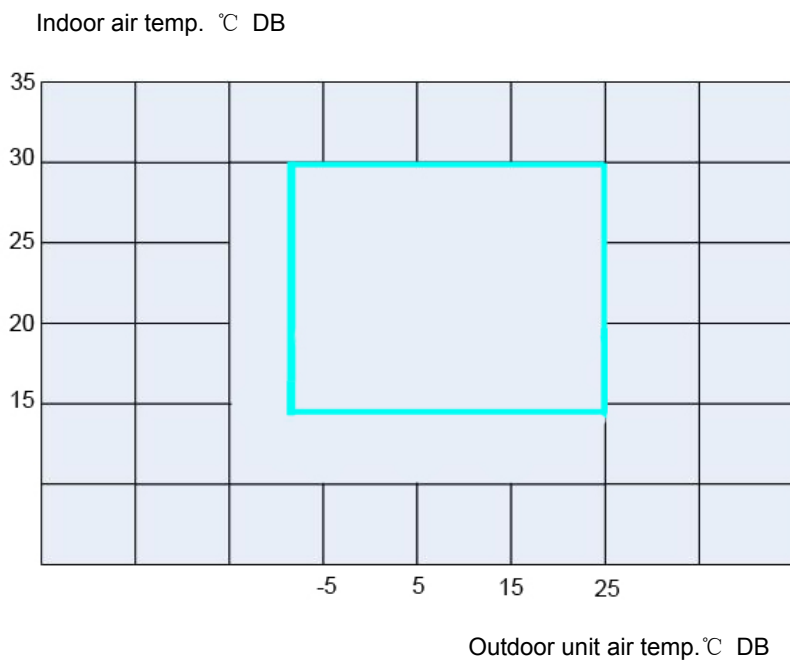

**Note:** The chart is the result from the continuous operation under constant air temperature conditions. However, excludes the initial pull-down stage.

# 5 Wiring diagram

MSV1-07CRN1 MSV1-09CRN1 MSV1-12CRN1

Indoor unit:

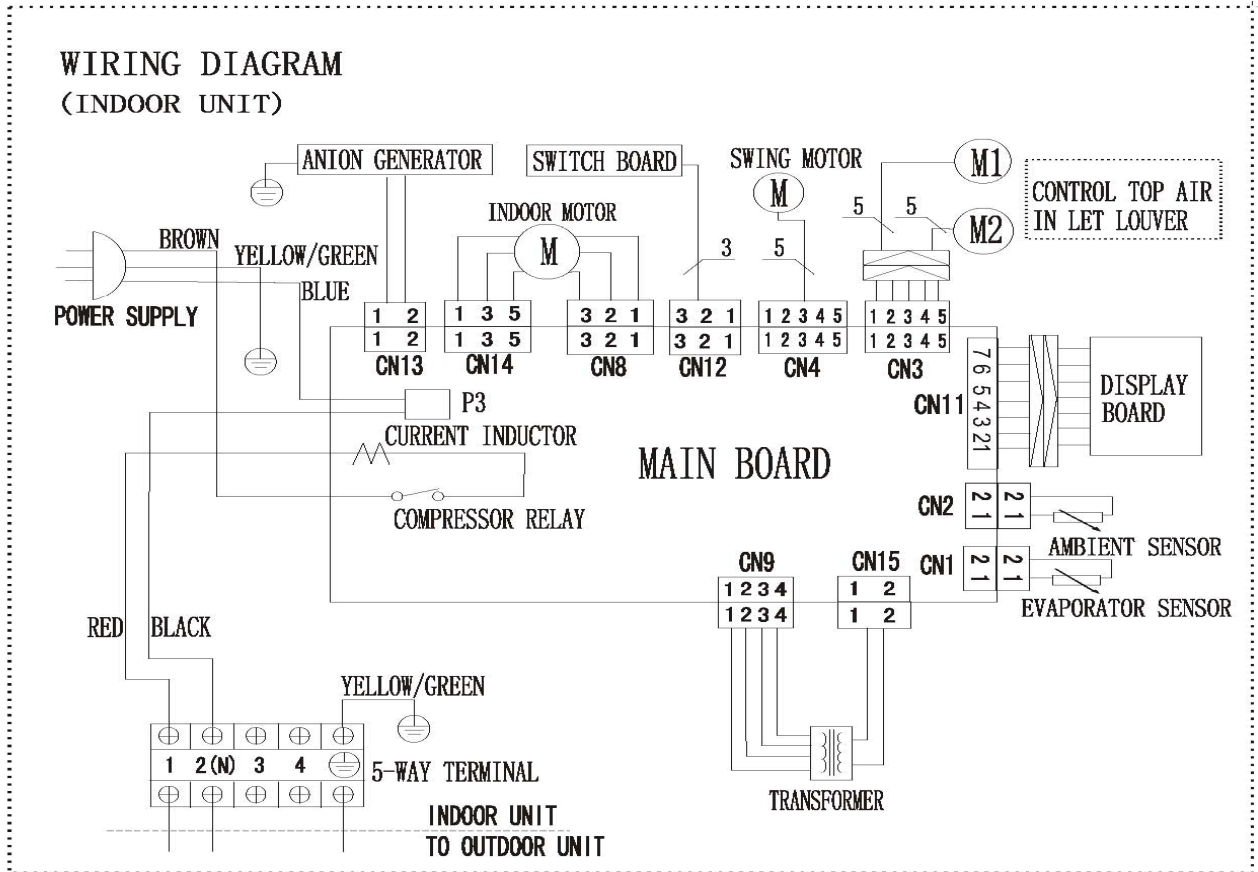

outdoor unit:

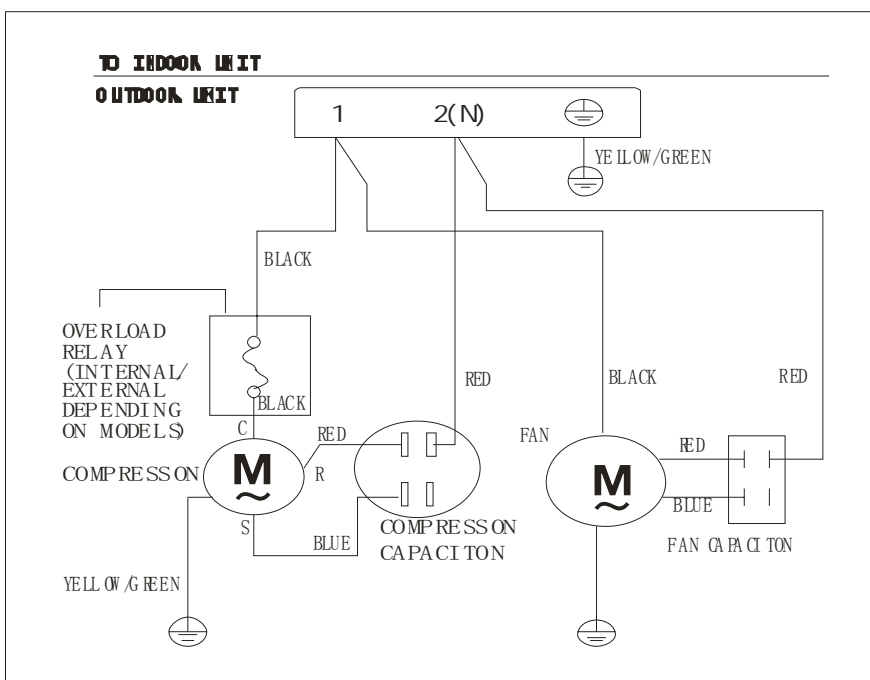

MSV1-07HRN1 MSV1-09HRN1 MSV1-12HRN1

Indoor unit:

WIRING DIAGRAM  
(INDOOR UNIT)

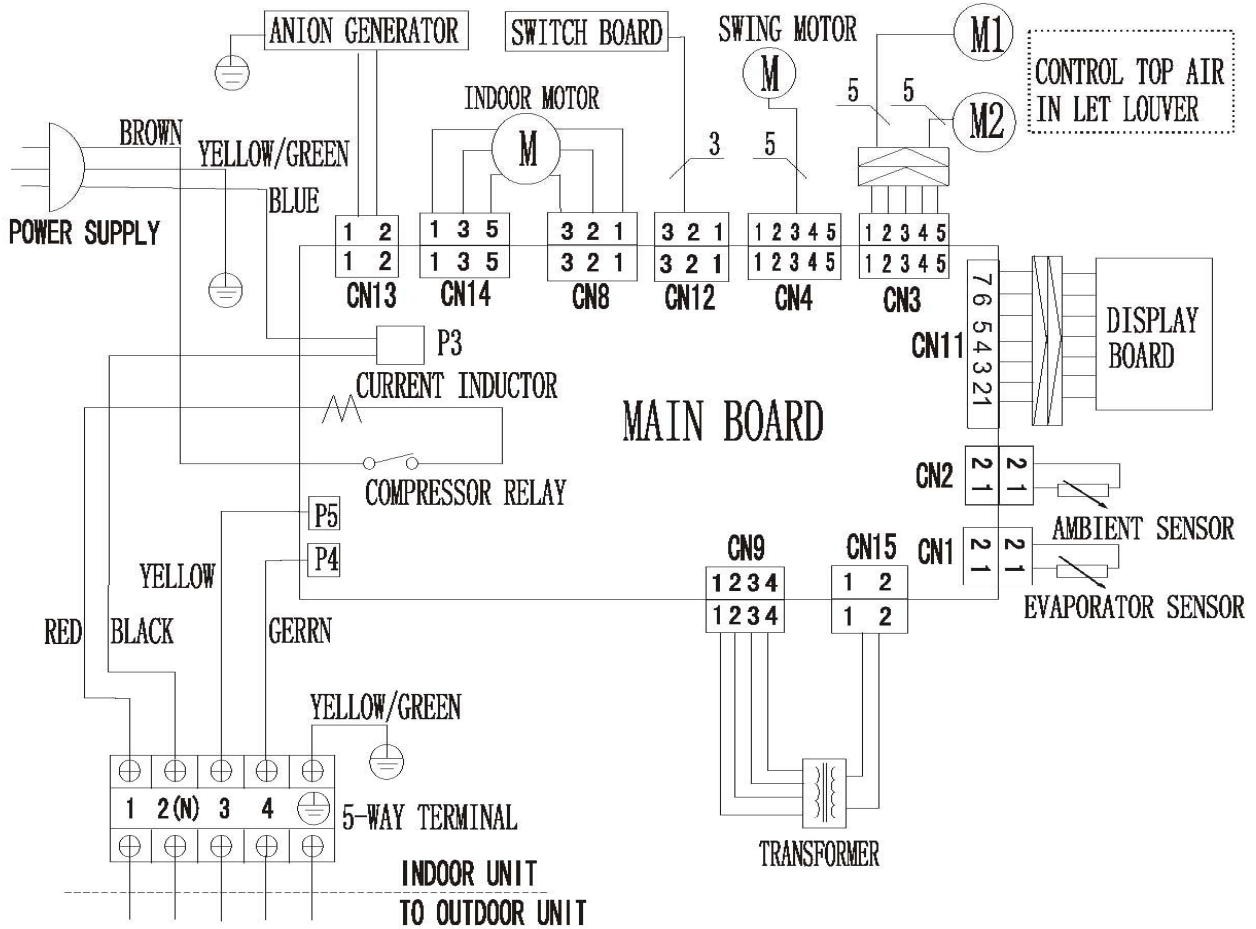

outdoor unit:

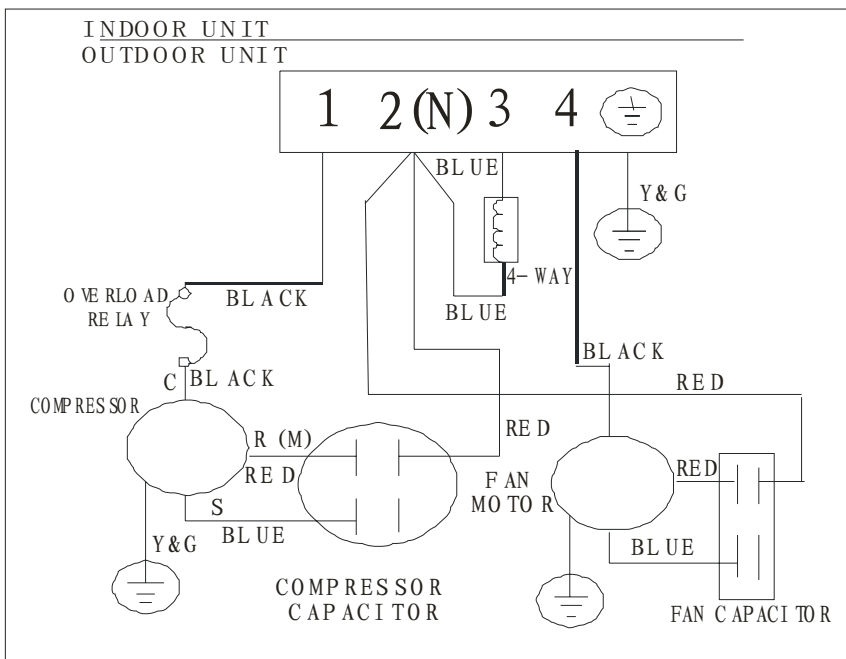

## 6 Installation details

### 6.1 Wrench torque sheet for installation

Outside diameter		Torque
mm	inch	Kg.m
φ6.35	1/4	1.8
φ9.52	3/8	4.2
φ12.7	1/2	5.5
φ15.88	5/8	6.6
φ19.05	3/4	6.6

### 6.2 Connecting the cables

The power cord of connect should be selected according to the following specifications sheet.

Amp	Grade		
	10	15	20
mm <sup>2</sup>	1.0	1.5	2.5

### 6.3 Pipe length and the elevation

Capacity	Pipe size		Standard length	Max.	Max.	Additional
			(m)	Elevation	Elevation	refrigerant
Btu/h	GAS	LIQUID		B (m)	A (m)	(g/m)
7k~12K	3/8" (φ9.52)	1/4" (φ6.35)	5	5	10	30
	1/2" (φ12.7)	1/4" (φ6.35)	5	5	10	30
16K~28K	1/2" (φ12.7)	1/4" (φ6.35)	5	8	15	30
	5/8" (φ15.88)	1/4" (φ6.35)	5	10	20	30
	5/8" (φ15.88)	3/8" (φ9.52)	5	10	20	65
30K~36K	5/8" (φ15.88)	3/8" (φ9.52)	5	15	30	65
	3/4" (φ19.05)	3/8" (φ9.52)	5	15	30	65



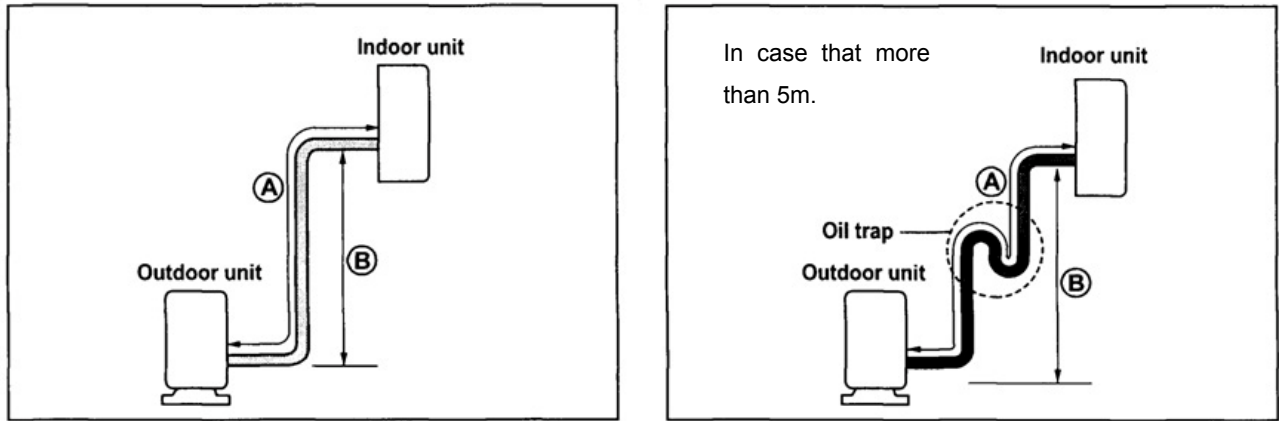

**Caution:**

Capacity is base on standard length and maximum allowance length is base of reliability.  
 Oil trap should be install per 5-7 meters.

## 6.4 Air purging of the piping and indoor unit

**Required tools:**

Hexagonal wrench; adjustable wrench; torque wrenches, wrench to hold the joints and gas leak detector.

**Note:**

The air in the indoor unit and in the piping must be purged. If air remains in the refrigeration piping, it will affect the compressor, reduce the cooling capacity, and could lead to a malfunction of unit.

Be sure, using a torque wrench to tighten the service port cap (after using the service port), so that it prevents the gas leakage from the refrigeration cycle.

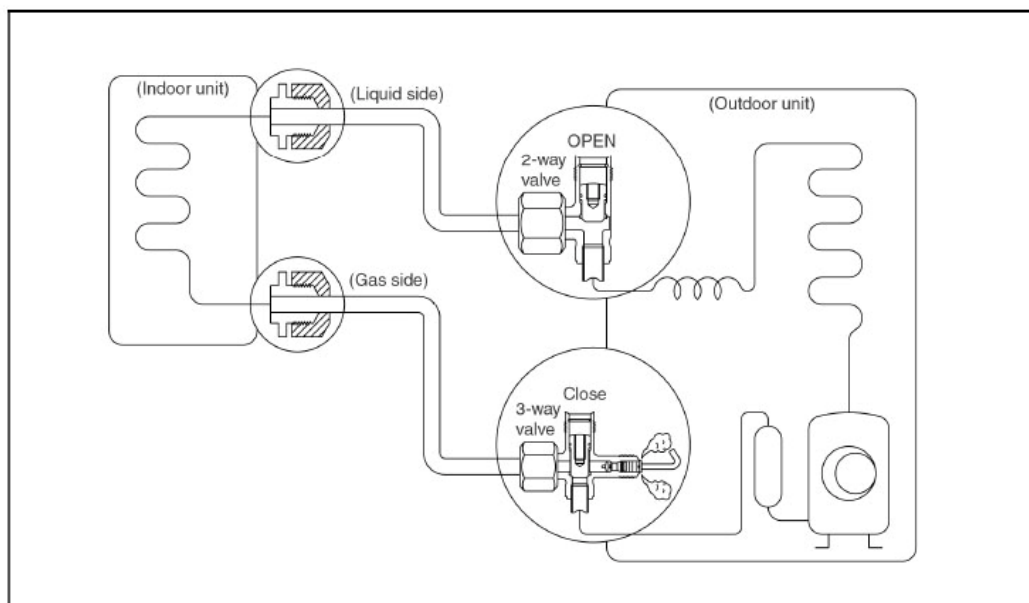

**Procedure:**

1. Recheck the piping connections.
2. Open the valve stem of the 2-way valve counterclockwise approximately 90°, wait 10 seconds, and then set it to closed position.

**Be sure to use a hexagonal wrench to operate the valve stem**

3. Check for gas leakage.  
**Check the flare connection for gas leakage**
4. Purge the air from the system.
5. Set the 2-way valve to the open position and remove the cap from the 3-way valve's service port.
6. Using the hexagonal wrench to press the valve core pin, discharge for three seconds and then wait for one minute.
7. Use torque wrench to tighten the service port cap to a torque of 1.8 kg.m. (18n.m)
8. Set the 3-way valve to the opened position.
9. Mounted the valve stem nuts to the 2-way and 3-way valves.
10. Check for gas leakage.
11. At this time, especially check for gas leakage from the 2-way and 3-way stem nuts, and from the service port.

**Caution:**

**If gas leakage is discovered in step (3) above, take the following measures.**

**If the leaks stop when the piping connections are tightened further, continue working from step (4).**

**If the gas leaks do not stop when the connections are retightened, repair the location of the leak, discharge all of the gas through the service port, and then recharge with the specified amount of gas from a gas cylinder.**

## 6.5 Pumping down (Re-installation)

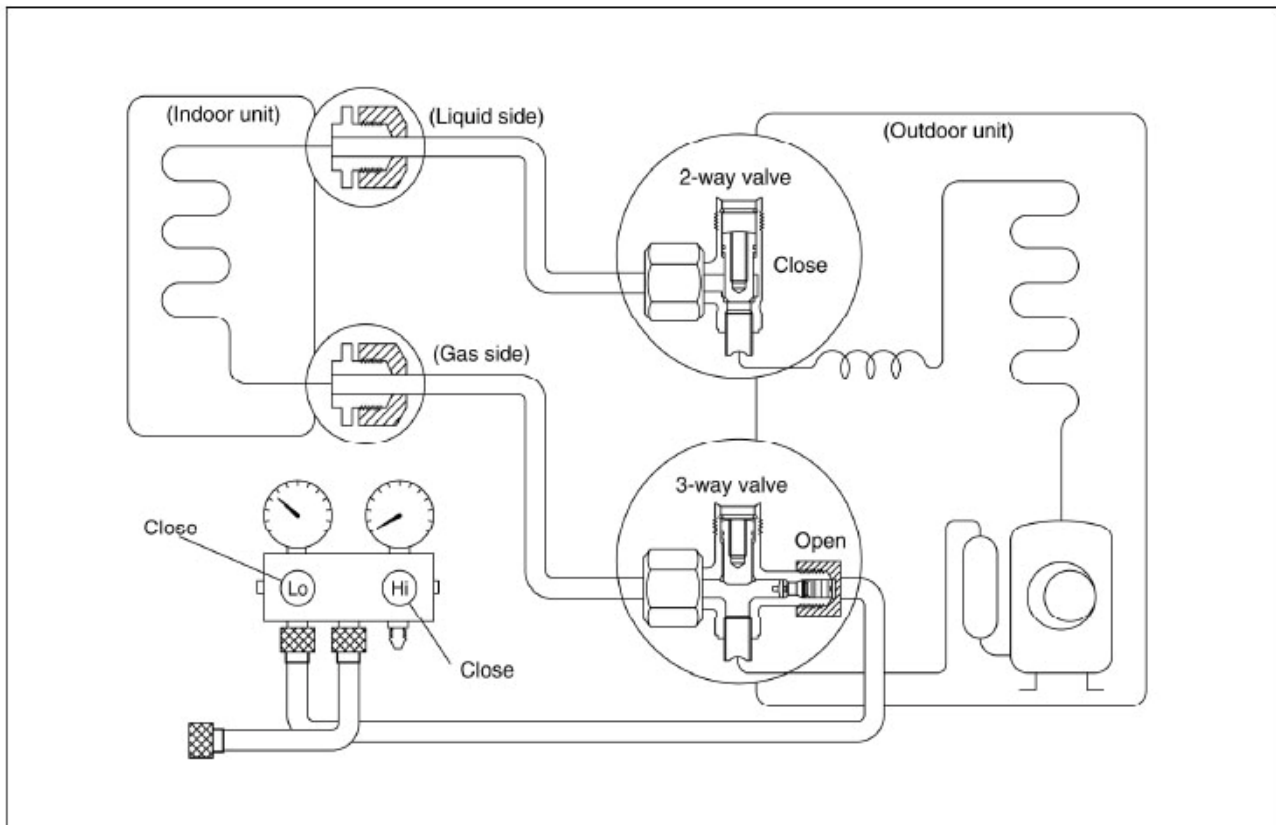

### Procedure:

1. Confirm that both the 2-way and 3-way valves are set to the opened position.  
**Remove the valve stem caps and confirm that the valve stems are in the opened position.**  
**Be sure to use a hexagonal wrench to operate the valve stems.**
2. Operate the unit for 10 to 15 minutes.
3. Stop operation and wait for 3 minutes, then connect the charge set to the service port of the 3-way valve.  
**Connect the charge hose with the push pin to the gas service port.**
4. Air purging of the charge hose.  
**Open the low-pressure valve on the charge set slightly to purge air from the charge hose.**
5. Set the 2-way valve to the close position.
6. Operate the air conditioner at the cooling cycle and stop it when the gauge indicates 0.1MPa.
7. Immediately set the 3-way valve to the closed position.  
**Do this quickly so that the gauge ends up indicating 0.3 to 0.5Mpa.**
8. Disconnect the charge set, and amount the 2-way and 3-way valve's stem nuts and service port caps.  
**Use a torque wrench to tighten the service port cap to a torque of 1.8 kg.m.**  
**Be sure to check for gas leakage.**

## 6.6 Re-air purging (Re-installation)

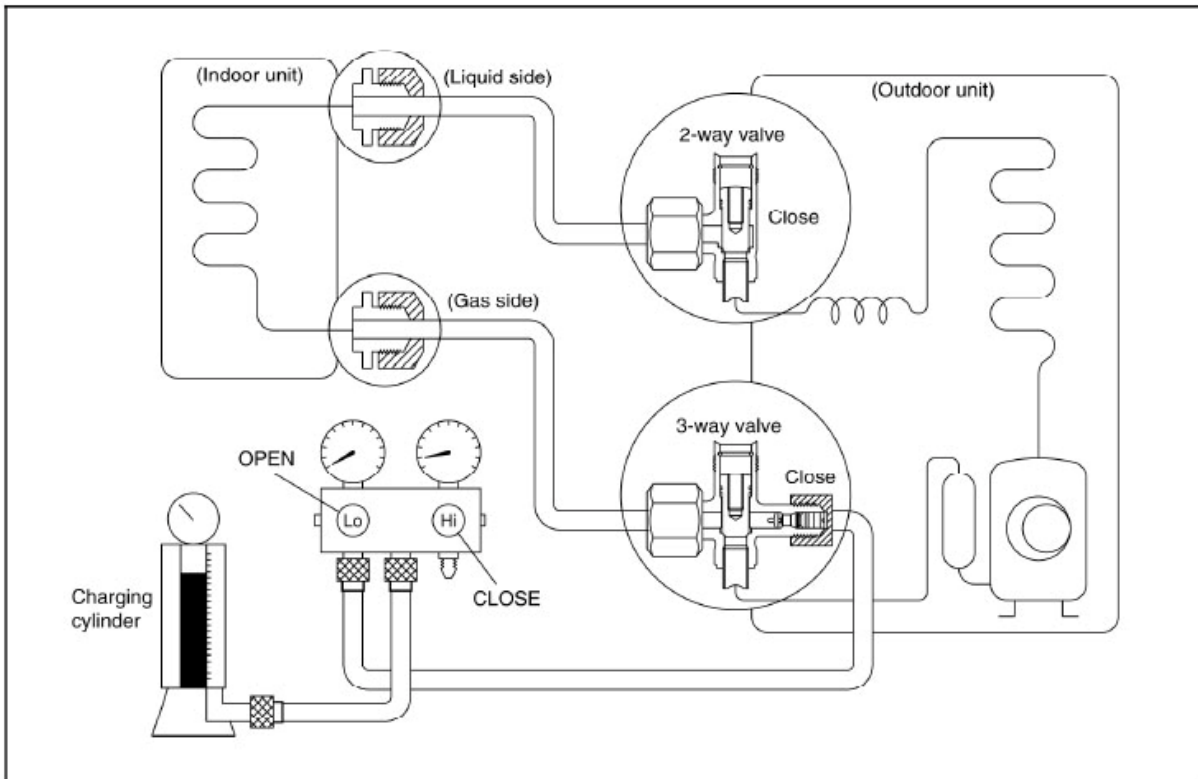

### Procedure:

1. Confirm that both the 2-way and 3-way valves are set to the closed position.
2. Connect the charge set and a charging cylinder to the service port of the 3-way valve.
3. Leave the valve on the charging cylinder closed.
4. Air purging.
5. Open the valves on the charging cylinder and the charge set. Purge the air by loosening the flare nut on the 2-way valve approximately 45° for 3 seconds then closing it for 1 minutes; repeat 3 times.
6. After purging the air, use a torque wrench to tighten the flare nut to on the 2-way valve.
7. Check the gas leakage.
8. Check the flare connections for gas leakage.
9. Discharge the refrigerant.
10. Close the valve on the charging cylinder and discharge the refrigerant until the gauge indicate 0.3 to 0.5 Mpa.
11. Disconnect the charge set and the charging cylinder, and set the 2-way and 3-way valves to the open position.
12. Be sure to use a hexagonal wrench to operate the valve stems.
13. Mount the valve stems nuts and the service port cap.

**Be sure to use a torque wrench to tighten the service port cap to a torque 18N.m.**

**Be sure to check the gas leakage.**

## 6.7 Balance refrigerant of the 2-way, 3-way valves

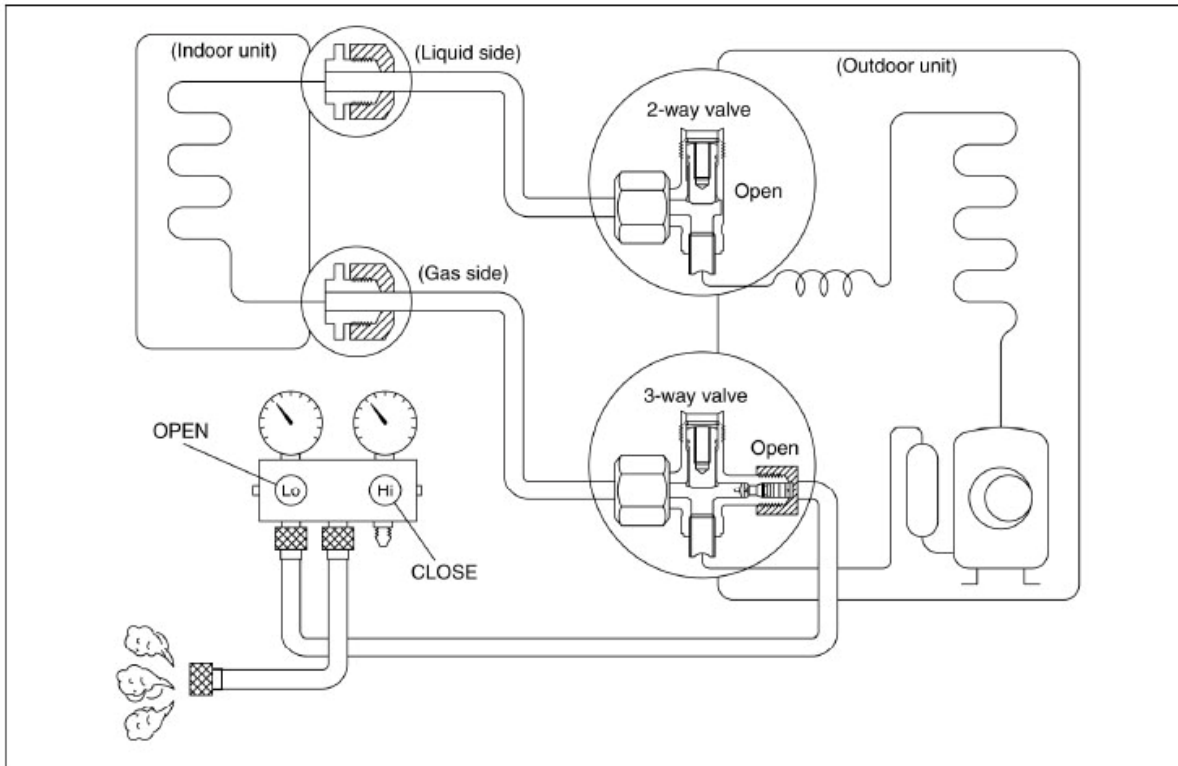

### Procedure:

1. Confirm that both the 2-way and 3-way valves are set to the open position.
2. Connect the charge set to the 3-way valve's service port.  
 Leave the valve on the charge set closed.  
 Connect the charge hose with the push pin to the service port.
3. Open the valves (Low side) on the charge set and discharge the refrigerant until the gauge indicates 0.05 to 0.1 Mpa.  
 If there is no air in the refrigeration cycle [the pressure when the air conditioner is not running is higher than 0.1Mpa, discharge the refrigerant until the gauge indicates 0.05 to 0.1 Mpa. If this is the case, it will not be necessary to apply a evacuation.  
 Discharge the refrigeration gradually; if it is discharged too suddenly, the refrigeration oil will be discharged.

## 6.8 Evacuation

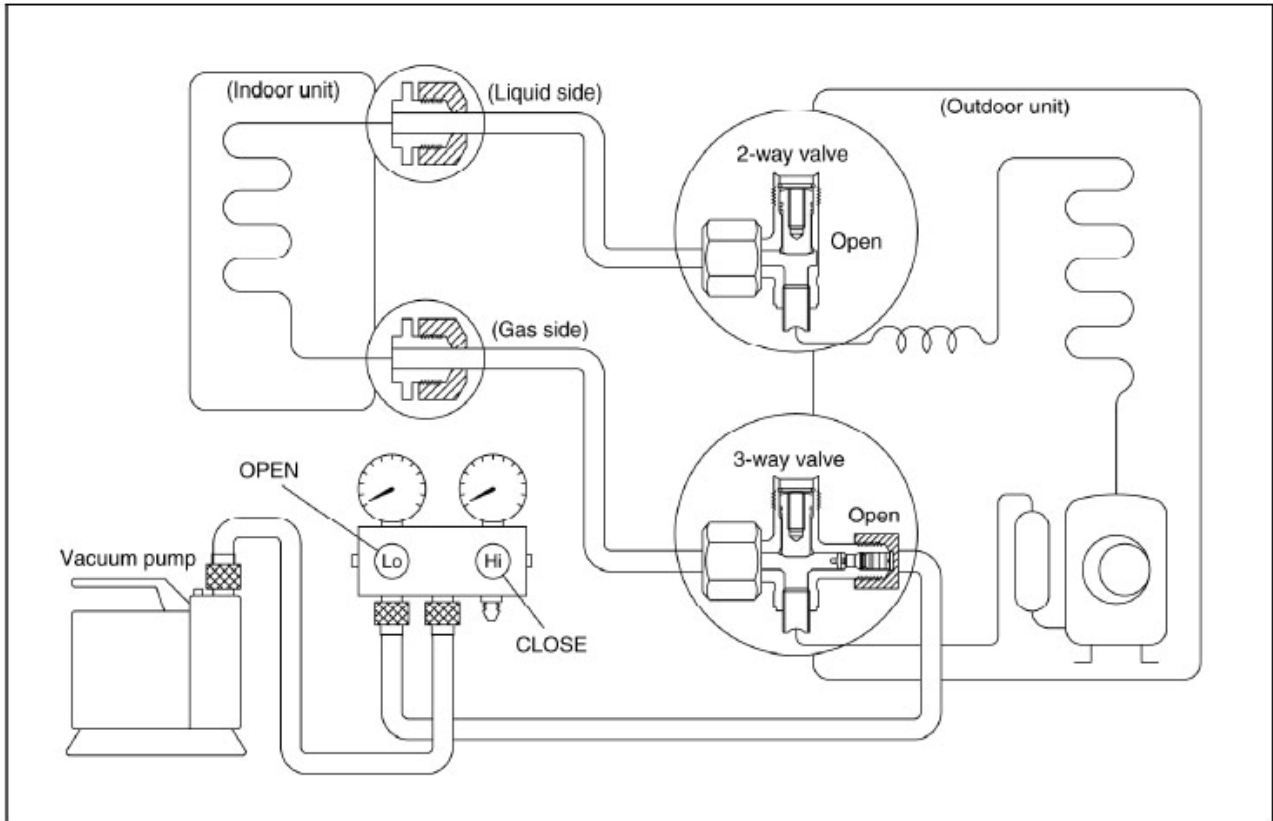

### Procedure:

1. Connect the vacuum pump to the charge set's centre hose.
2. Evacuation for approximately one hour.  
**Confirm that the gauge needle has moved toward -0.1 Mpa (-76 cmHg) [vacuum of 4 mmHg or less].**
3. Close the valve (Low side) on the charge set, turn off the vacuum pump, and confirm that the gauge needle does not move (approximately 5 minutes after turning off the vacuum pump).
4. Disconnect the charge hose from the vacuum pump.  
**Vacuum pump oil, if the vacuum pump oil becomes dirty or depleted, replenish as needed.**

## 6.9 Gas charging

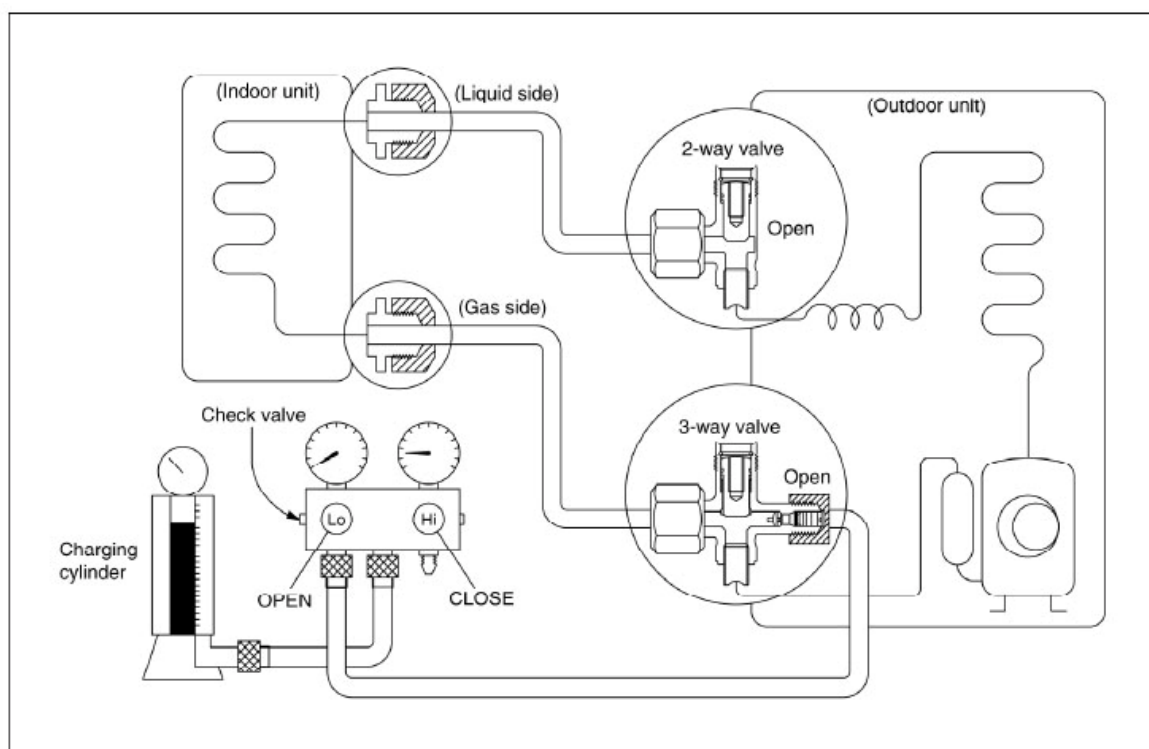

### Procedure:

1. Connect the charge hose to the charging cylinder.

Connect the charge hose which you disconnected from the vacuum pump to the valve at the bottom of the cylinder.

2. Purge the air from the charge hose.

Open the valve at the bottom of the cylinder and press the check valve on the charge set to purge the air (be careful of the liquid refrigerant).

3. Open the valves (Low side) on the charge set and charge the system with liquid refrigerant.

If the system cannot be charge with the specified amount of refrigerant, it can be charged with a little at a time (approximately 150g each time) while operating the air conditioner in the cooling cycle; however, one time is not sufficient, wait approximately 1 minute and then repeat the procedure.(pumping down-pin).

4. Immediately disconnect the charge hose from the 3-way valve's service port.

Stopping partway will allow the refrigerant to be discharged.

If the system has been charged with liquid refrigerant while operating the air conditioner, turn off the air conditioner before disconnecting the hose.

5. Mounted the valve stem caps and the service port

Use torque wrench to tighten the service port cap to a torque of 18N.m.

Be sure to check for gas leakage.

# 7 Electronic function

## 7.1 Electronic control working environment

Input voltage: 198~253V

Input power frequency: 50/60Hz

Ambient temperature: -7°C+43°C

Indoor fan normal working amp is less than 1A

Outdoor fan normal working amp is less than 1.5A

Four-way valve normal working amp is less than 1A

Swing motor: DC12V

Compressor: single-phase power supply. Its normal working amp is less than 15A

## 7.2 Proper symbols and their meaning

TA: Indoor ambient temperature

TE: Indoor evaporator temperature

TS: Setting temperature through the remote controller

I3sec: Self-protection amp of compressor, continue three seconds until turns off the compressor.

I5MIN: Self-protection amp of compressor, continue five minutes until turns off the compressor.

IFAN: Self-protection amp of outdoor fan/indoor fans when they change from higher wind to lower wind.

IRESTORE: Amp self-protection return value

THDEFROST: High wind, defrosting temperature difference

TMDEFROST: Middle wind, defrosting temperature difference

TLDEFROST: Low wind, defrosting temperature difference

TE1: Anti-cold wind, from Fan Off to Breeze temperature

TE2: Anti-cold wind, from Breeze to Setting Fan Speed temperature

TE3: Anti-cold wind, from Setting Fan Speed to Breeze temperature

TE4: Anti-cold wind, from Breeze to Fan Off temperature

TE5: Evaporator low temperature protection entering temperature

TE6: Evaporator low temperature protection restoring temperature

TE7: Evaporator high temperature protection, compressor off temperature

TE8: Evaporator high temperature protection, fan off temperature

TE9: Evaporator high temperature protection, restoring temperature



## 7.3 Function

Remote receiving  
 Testing and forced running  
 Position set for indoor unit wind vane  
 LCD displaying and alarm  
 Timer On or off  
 Protection for the compressor  
 Current protection  
 High temperature protection of indoor heat exchanger at heating mode  
 Auto defrosting and heating recovery at heating mode  
 Anti cold air at heating mode  
 Anti frozen at cooling mode  
 Auto restart  
 Self-Clean

## 7.4 Protection

7.4.1 3 minutes delay at restart for compressor.

7.4.2 Sensor protection at open circuit and breaking disconnection

7.4.3 Fan Speed is out of control. When Indoor Fan Speed is too high(higher than High Fan+300RPM)or too low(lower than 400RPM), the unit stops and LED displays failure information and can't returns to normal operation automatically.

7.4.4 Cross Zero signal error warning. If there is no Cross Zero signals in 4 minutes, the unit stops and LED displays failure information and can't returns to normal operation automatically.

7.4.5 The current protection of the compressor

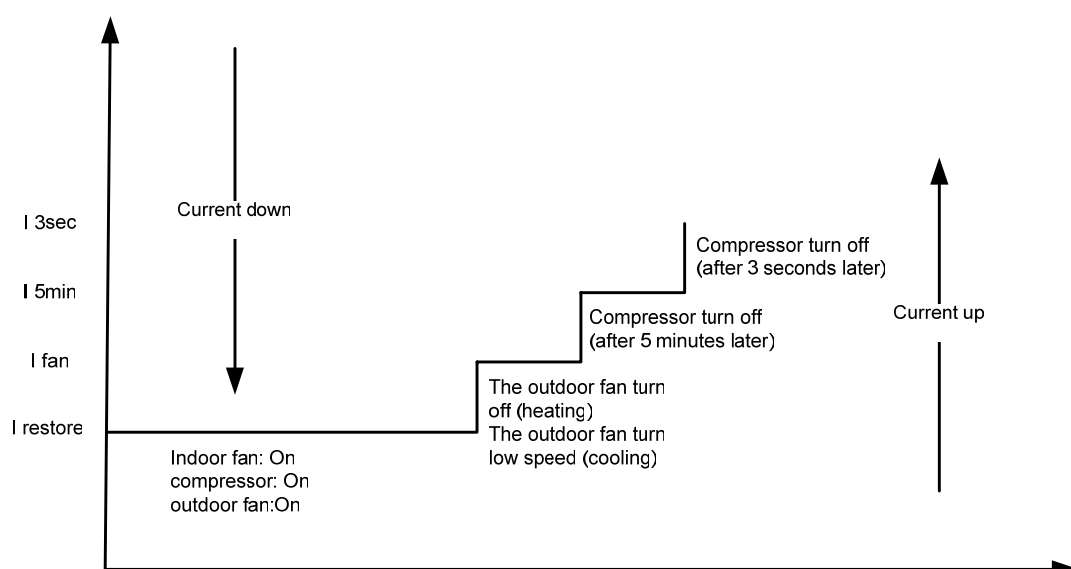

If compressor turns off for continuously 4 times due to current protection in 5 minutes from Compressor On, the unit stops and LCD displays failure information and can't returns to normal operation automatically.

## 7.5 Fan only mode

Fan speed is high/mid/low/ Auto

## 7.6 Cooling mode

The 4-way valve is closed at cooling mode.

The action of the compressor and the outdoor fan:(T=indoor temperature)

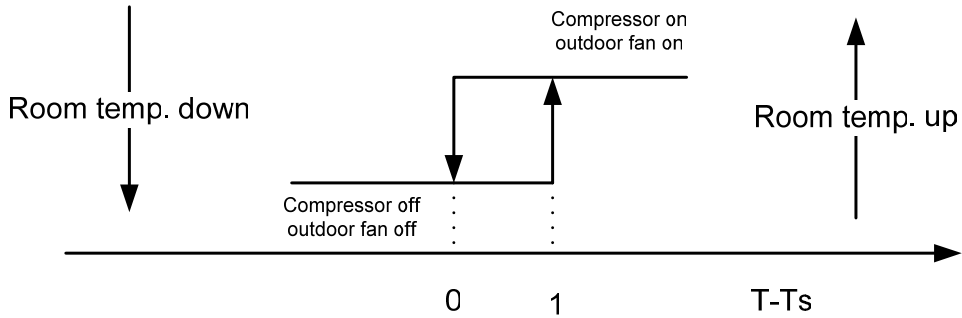

Auto fan at cooling mode:

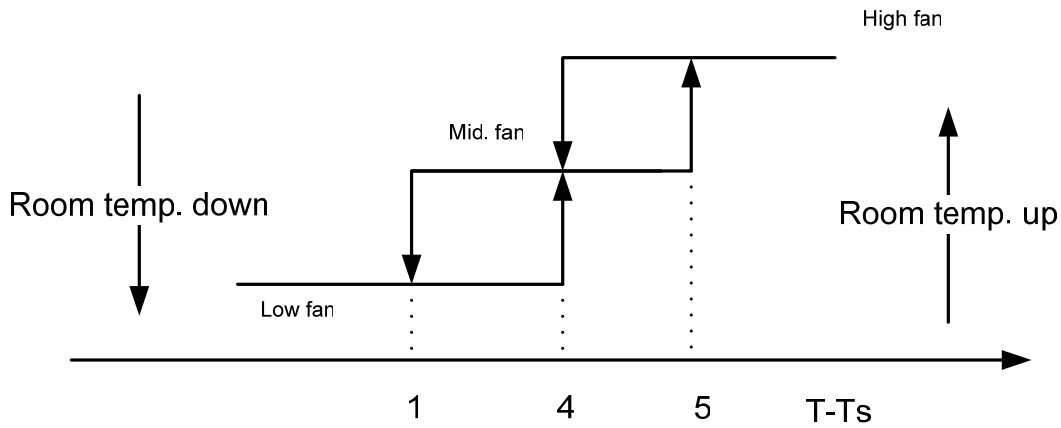

Anti-freezing control to indoor evaporator at cooling mode ( T: evaporator temp. )

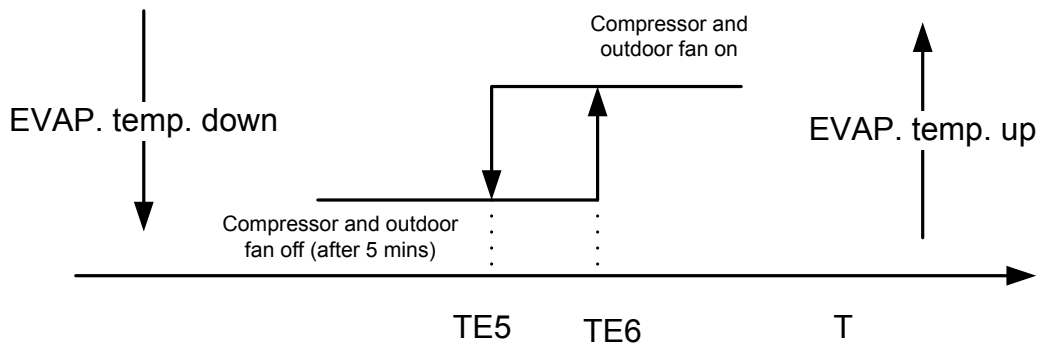

Condenser high temperature protection (only for heat pump)

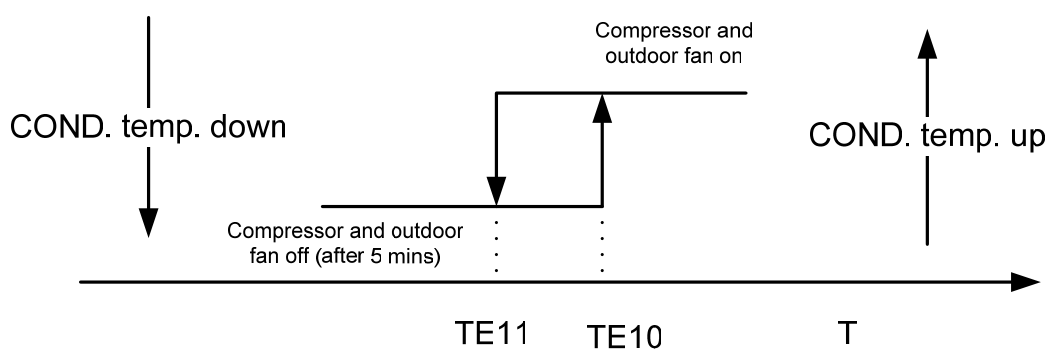

## 7.7 Dehumidifying mode

Indoor fan speed at low speed.

Protection is same as cooling mode.

## 7.8 Heating mode

7.8.1 Generally, the 4-way valve is open in heating mode, but it is closed in defrosting mode. 4-way valve must delay 2 minutes compared with compressor if the compressor changed into non-heating mode or turned off. 4-way valve doesn't delay in dehumidifying mode.

7.8.2 Generally, the outdoor fan is turned off with the on-off action of compressor in heating mode, except for the defrosting mode or the end of defrost.

7.8.3 Action of compressor and outdoor fan motor at heating mode: compressor must run for 7 minutes after starting and then judge temperature. Meanwhile other protections are still valid.

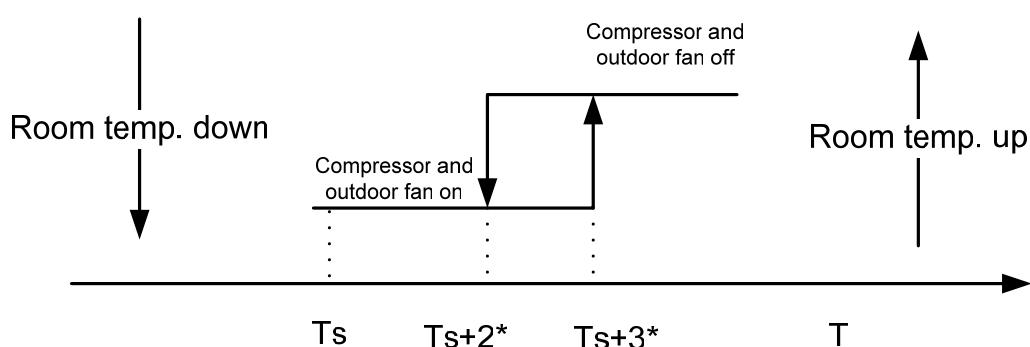

\* This parameter can be changed from 0 to 3

7.8.4 Indoor Fan actions at heating mode

Indoor Fan can be set at HIGH/MID/LOW/AUTO by using a remote controller, but Anti-cold wind function prevails.

Anti-cold wind control function at heating mode (T=indoor exchanger temp.)

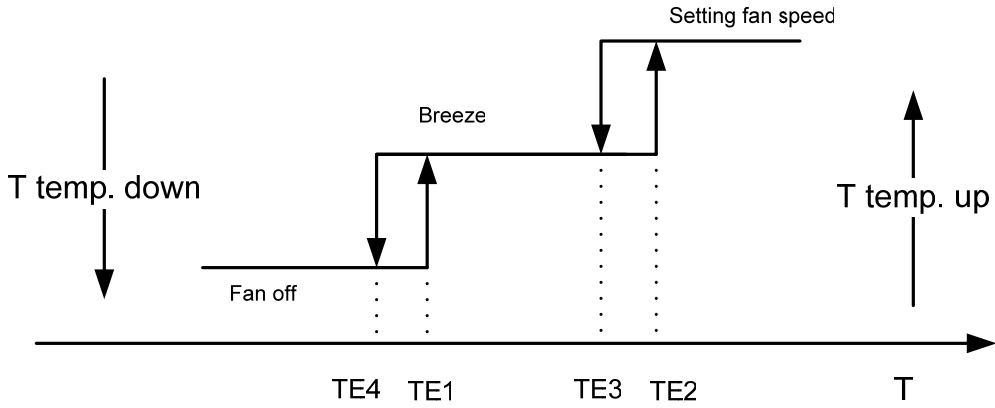

7.8.5 Auto wind at heating mode (T=indoor temp.)

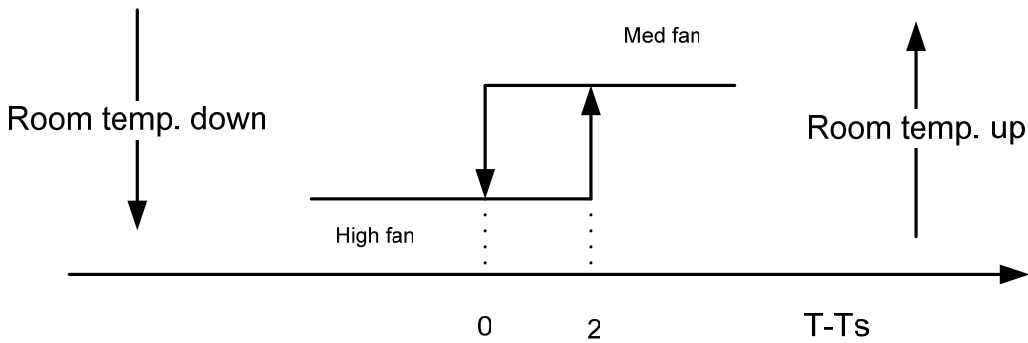

7.8.6 Indoor evaporator high-temperature protection at heating mode (T=indoor exchanger temp.)

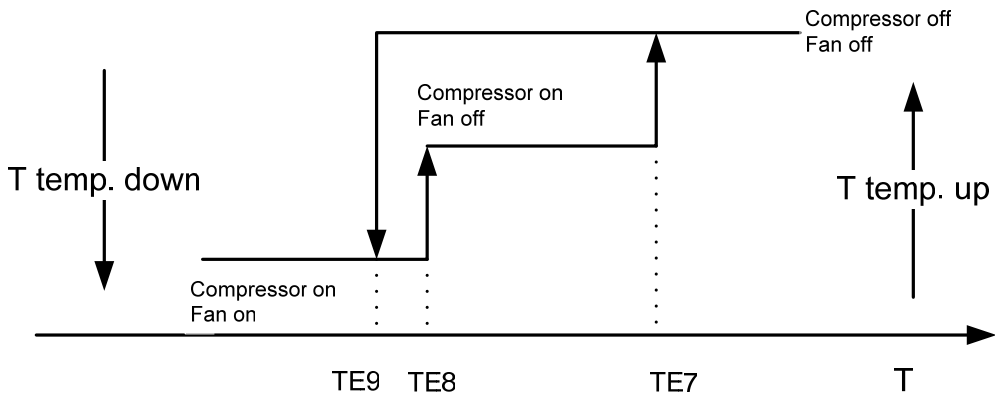

The louver opens to Standard Angle ANGLHEAT when power is on for the first time

## 7.9 Defrosting mode(available for heating mode)

7.9.1 Defrosting condition:

Defrost starts when either of the following:

T3 lower than 0°C, lasts for more than 40 minutes, provided that the time period then the temperature is lower than -3°C consecutively reaches 3 minutes.

Calculate from the end of latest defrost, evaporator high temp. protection only closes outdoor fan with the compressor still running. Add up to 90 minutes.

7.9.2 Conditions of defrost ending:

Defrosting ends when either of the following:

The time gets to 10 minutes.

$T_3 > 20^\circ\text{C}$ .

The circulation is as following:

### 7.9.3 Defrosting Actions

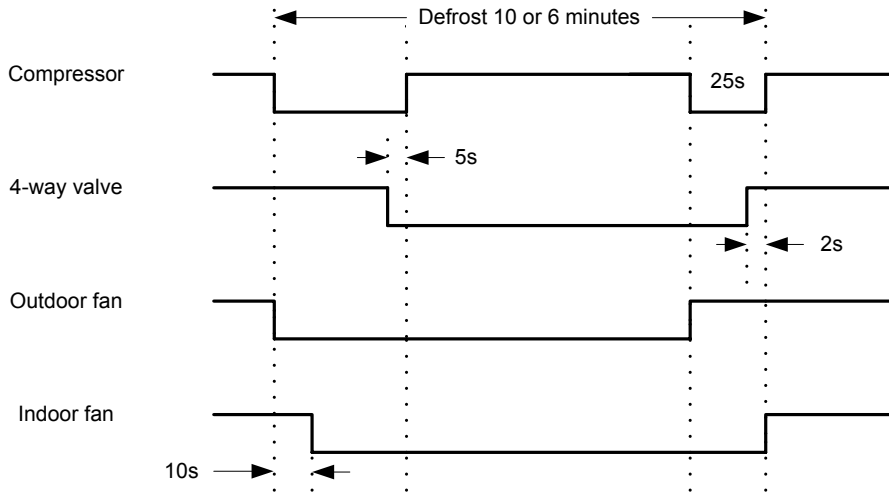

**Remark:** when the evaporator pipe temperature sensor more than TE16, the indoor fan start to run.

## 7.10 Auto mode

7.10.1 The air conditioner automatically selects one of the following operation modes: cooling, heating or fan only according to the temperature difference between room temperature (TA) and set temperature (TS).

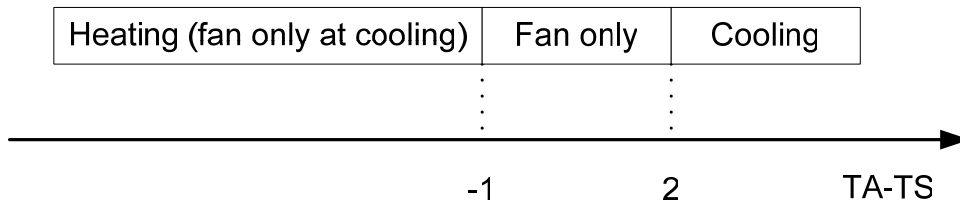

7.10.2 The indoor fan blows automatically in corresponding selected mode;

7.10.3 The motion of indoor fan's blade should accord with the selected operation mode;

7.10.4 One mode should be carried out for at least 15 minutes once selected. If the compressor cannot start for 15 minutes, reselect the operation mode according to the room temp. and set temp., or reselect when the set temp. varies

## 7.11 Force cooling function

7.11.1 Select forced cooling function with the forced cooling button or the switch

7.11.2 The compressor is unconditionally turned on, after 30 minutes cooling operation whose fan mode is set as low, the A/C operates at the DRY mode with a set temp. of  $24^\circ\text{C}$

7.11.3 All protections of remote control cooling are available at forced cooling operation

7.11.4 Forced Auto function

Select forced auto function with the forced auto button or the switch.

In forced auto status the A/C operates at remote control mode with a set temp. of 24°C

Manual operation is controlled by touching buttons and divided into force cooling and forced auto mode. It transfer between these two modes by pressing the buttons, the cycling order of the button press is as below graph show to you.

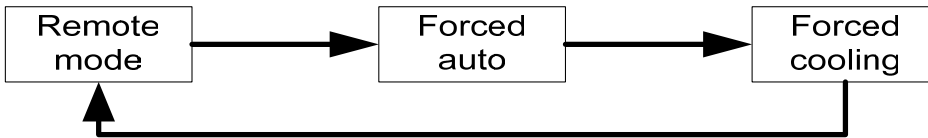

## 7.12 Sleep mode

7.12.1 The sleep function is available at cooling, heating or auto mode

7.12.2 Cooling:

The set temperature rise 1°C per hour. Two hours later, the set temperature will maintain as a constant and the fan speed is kept at low speed.

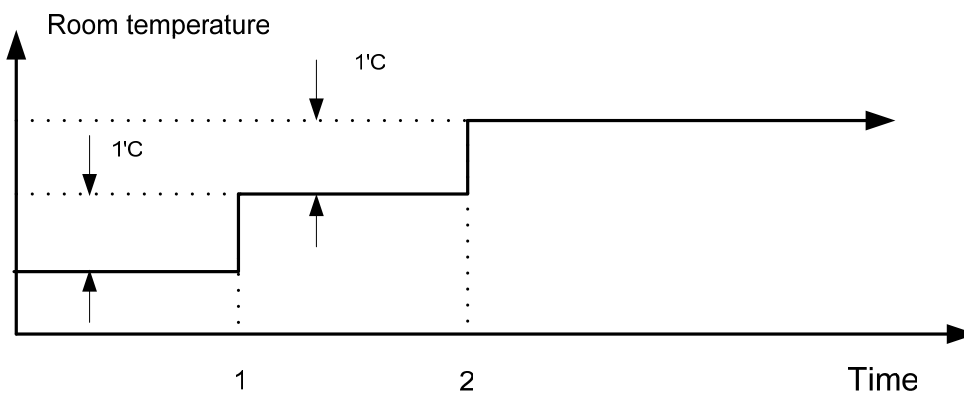

7.12.3 Heating:

The set temperature decrease 1°C per hour. Two hours later, the set temperature will maintain as a constant and the air circulation is kept at low speed (Anti-cold function takes precedence over all).

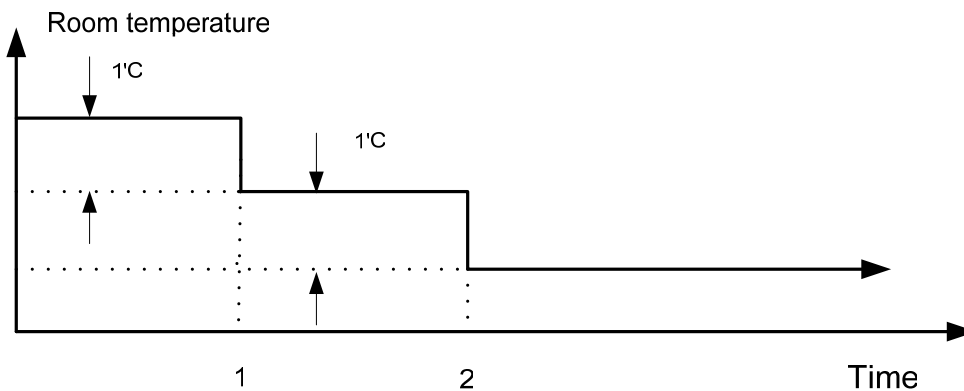

7.12.4 Auto:

After an hour running under economic mode, the set temp will rise 1°C, if it is under cooling mode; the set temp will decrease 1°C, if it is under heating mode; the set temp will be changeless, if it is under fan-only mode; the condition will be the same after the air conditioner running under economic mode

after 2 hours, and during the next time the set temp do not change. The total time is 7 hours, after 7 hours the unit stops.

## **7.13 Auto restart function**

In case of a sudden power failure, this function automatically sets the unit to previous settings before the power failure when power returns.

## **7.14 Ionizer (air clean) function**

7.14.1 Ionizer (air clean) function is effected when the unit is working and controlled by the remote controller.

7.14.2 This function is active when the unit received the signal from the remote controller first time and inactive when received the signal again. Repeat this circle when received signal again.

7.14.3 This function is working only when the indoor fan is working.

7.14.3 This function will not stop when the working mode changed, and be inactive when the unit shut down.

## 8 Model and Parameters

Model	7K	9K	12K
DELAY_TIME	127sec	127sec	127sec
DEFROST_TIME	7.5min	7.5min	7.5min
I3SEC	7.5	10.0	12.0
I5MIN	6.2	7.5	8.5
IFAN	5.2	6.0	7.5
IRESTORE	4.2	5.0	6.5
IDEFROST	3.2	3.5	5.0
TE1	28	28	34
TE2	32	32	37
TE3	30	30	33
TE4	26	26	22
TE5	4	4	4
TE6	10	10	10
TE7	60	60	63
TE8	53	53	53
TE9	50	50	52
THDEFROST	15	17	18
TMDEFROST	16	18	19
TLDEFROST	17	19	20
ANGLRANGE	196	196	196
ANGLOFF	100	100	100
ANGLCOOL	180	180	180
ANGLHEAT	22	22	22
ANGLCSL	8	8	8
ANGLCSH	40	40	40
ANGLHSL	8	8	8
ANGLHSH	40	40	40
ANGLDL	8	8	8
ANGLDH	190	190	190
ANGLFL	50	50	50
ANGLFH	155	155	155
HSPEEDH	1000	1080	1280
HSPEEDM	900	950	1060
HSPEEDL	800	800	900
HSPEEDS	750	750	750
CSPEEDP	1080	1080	1280
CSPEEDH	1040	1040	1260
CSPEEDM	900	900	1080
CSPEEDL	800	800	900
CSPEEDS	750	750	750



# 9 Troubleshooting

## 9.1 LCD Display board

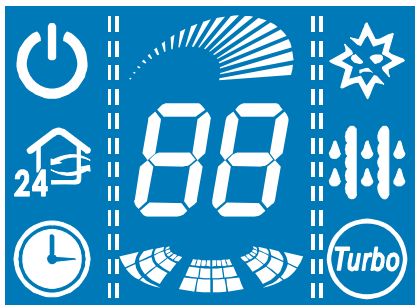

### ON/OFF indicator



This indicator illuminates when the air conditioner is in operation.

### PRE.-DEF. Indicator (For Cooling & Heating models only)



This indicator illuminates when the air conditioner starts defrosting automatically or when the warm air control feature is activated in heating mode.

### Turbo indicator



This indicator illuminates when the air conditioner is in turbo operation.

### TEMPERATURE indicator



Usually it displays the temperature settings.

### TIMER indicator



This indicator illuminates when TIMER is set ON/OFF.

### FAN SPEED indicator



This indicator illuminates when change the fan speed.

### AUTOCEPHALY AIR EXCHANGING indicator



This indicator illuminates when the indoor air exchange with the outdoor air.

## 9.2 Indoor Unit Error Display

Display	STATUS
E1	EEPROM error
E2	Zero-crossing examination error
E3	Fan speed beyond control
E4	Over current protection of the compressor occurs 4 times
E5	Open or short circuit of Room temperature sensor
E6	evaporator temperature sensor open or short circuit of

## 9.3 Diagnostic chart

After energizing, no indicator is lighted and the air conditioner can't be operated.

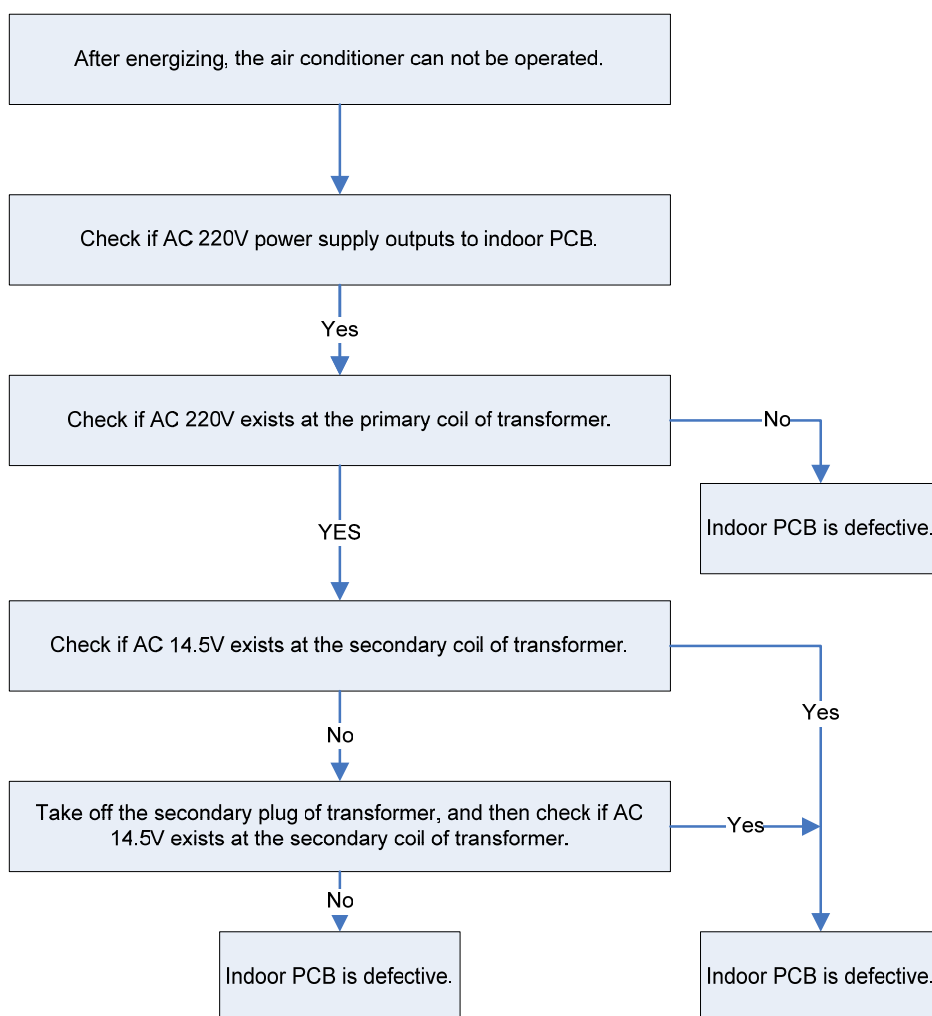

## 9.4 Resetting phenomenon often occurs during operation.

(That is automatically entering to the status when power is on.)

The reason is that the instantaneous voltage of main chip is less than 4.5V. Check according to the following procedure:

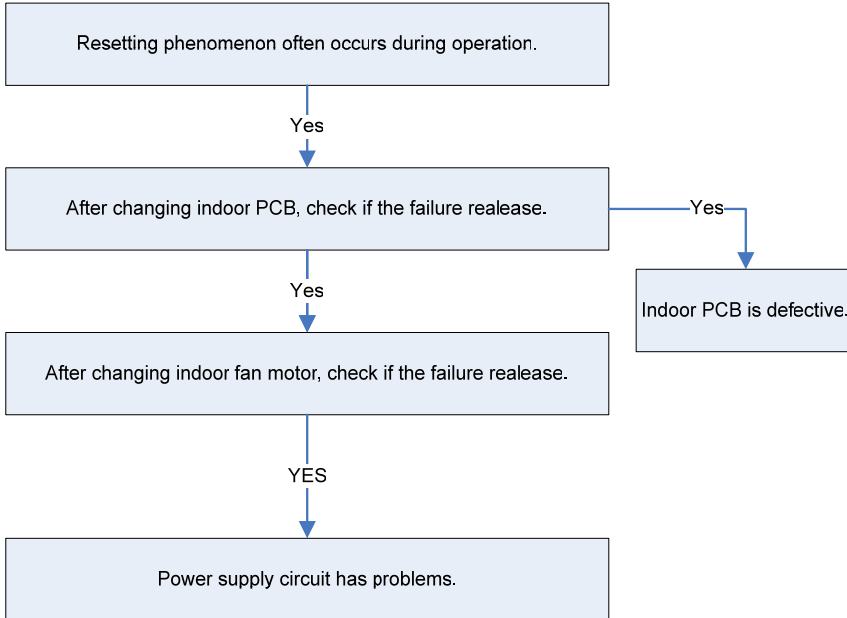

## 9.5 Operation lamp flashes and Timer lamp off.

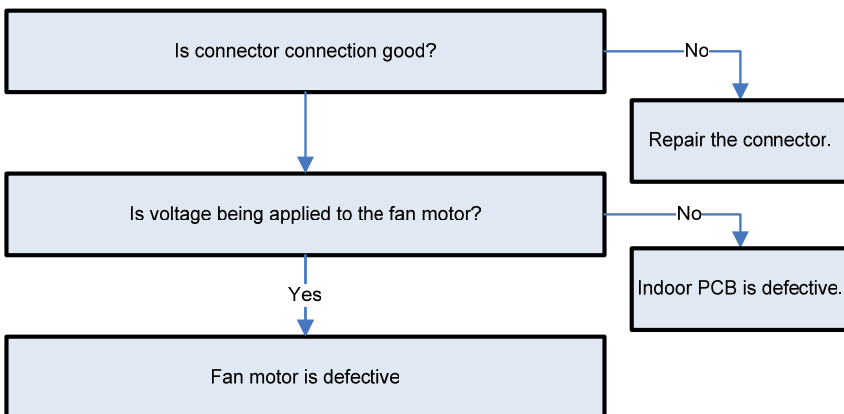

## 9.6 Operation lamp flashes and Timer lamp on.

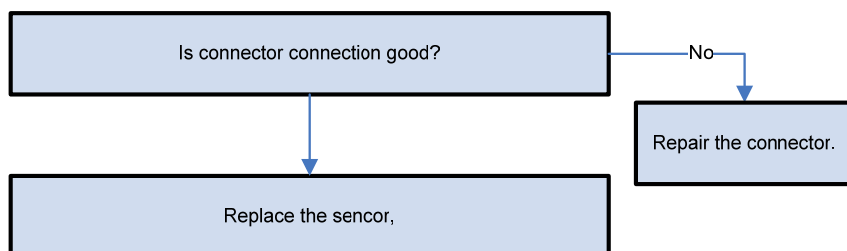

## 9.7 Operation lamp off and Timer lamp flashes

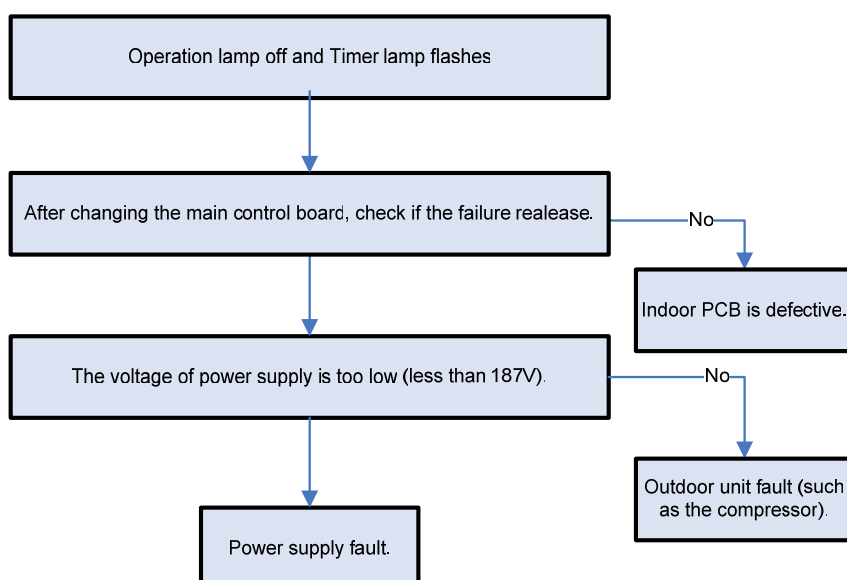

## 9.8 Operation lamp on and Timer lamp flashes

EEROM error, indoor PCB is defective.

## 9.9 Operation lamp flashes, Timer lamp flashes .

This is alarm signal when the main chip can't detect over-zero signal. When such failure occurs, the main control board must have fault.

## Characteristic of temperature sensor

Temp. °C	Resistance KΩ	Temp. °C	Resistance KΩ	Temp. °C	Resistance KΩ
-10	62.2756	17	14.6181	44	4.3874
-9	58.7079	18	13.918	45	4.2126
-8	56.3694	19	13.2631	46	4.0459
-7	52.2438	20	12.6431	47	3.8867
-6	49.3161	21	12.0561	48	3.7348
-5	46.5725	22	11.5	49	3.5896
-4	44	23	10.9731	50	3.451
-3	41.5878	24	10.4736	51	3.3185
-2	39.8239	25	10	52	3.1918
-1	37.1988	26	9.5507	53	3.0707
0	35.2024	27	9.1245	54	2.959
1	33.3269	28	8.7198	55	2.8442
2	31.5635	29	8.3357	56	2.7382
3	29.9058	30	7.9708	57	2.6368
4	28.3459	31	7.6241	58	2.5397
5	26.8778	32	7.2946	59	2.4468
6	25.4954	33	6.9814	60	2.3577
7	24.1932	34	6.6835	61	2.2725
8	22.5662	35	6.4002	62	2.1907
9	21.8094	36	6.1306	63	2.1124
10	20.7184	37	5.8736	64	2.0373
11	19.6891	38	5.6296	65	1.9653
12	18.7177	39	5.3969	66	1.8963
13	17.8005	40	5.1752	67	1.83
14	16.9341	41	4.9639	68	1.7665
15	16.1156	42	4.7625	69	1.7055
16	15.3418	43	4.5705	70	1.6469